



Jergens[®]

OPEN UP YOUR FIVE-AXIS MACHINING POSSIBILITIES

FIXTURE-PRO[®] SELF-CENTERING VISE LINE





FIXTURE-PRO® SELF-CENTERING VISE LINE

Jergens latest family of self-centering vises has been engineered to be the ideal solution for low profile five-axis workholding. Available in both 130mm and 75mm widths, they can accommodate a wide array of workpiece sizes. The quick change jaws incorporate a pull down feature to actively minimize jaw lift. Multiple jaw styles make this vise system configurable for most workholding needs, from first operation to finish work.

Clamping Force:

- 75mm vises: 3,500 lbs @ 50 ft*lbs
- 130mm vises: 3,600 lbs @50 ft*lbs
- Leadscrew features rolled trapezoidal threads for superior strength and durability
- Low friction surface treatment of critical components improves performance and reduces wear

VERSATILE MOUNTING OPTIONS

Vises easily mount to a number of modular fixture platforms, adding to Jergens industry leading selection of quick change fixturing.

FIXTURE-PRO® QUICK LOCATING SYSTEM (QLS)

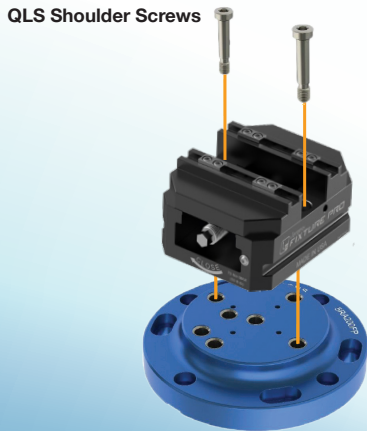

Fixture-Pro® Base Element with QLS Grid on 50mm

*75mm vises require adapter plate (5VA13075) for QLS Mounting

PALLET MOUNTING

- Quick-Loc™
- Drop-n-Lock™

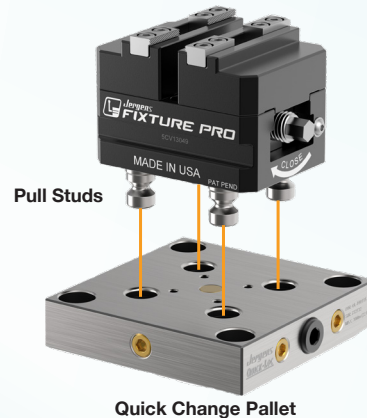

PALLET COMPATIBILITY

Pallet System	Pull Stud Part No.	75mm Vise	130mm Vise
52mm Quick-loc	QL-200800	♦	♦
96mm Quick-loc	QL-200805		♦
60mm Drop-n-Lock	5QP020		♦



75MM SELF-CENTERING VISE

- Available in 100mm or 160mm lengths
- Vises can be ordered with alternate jaw types by adding the one of the following suffixes to a base part number:
 - **A** for aluminum soft jaws
 - **H** for hardened step jaws
 - **S** for steel soft jaws
 - **IN** for insert jaws

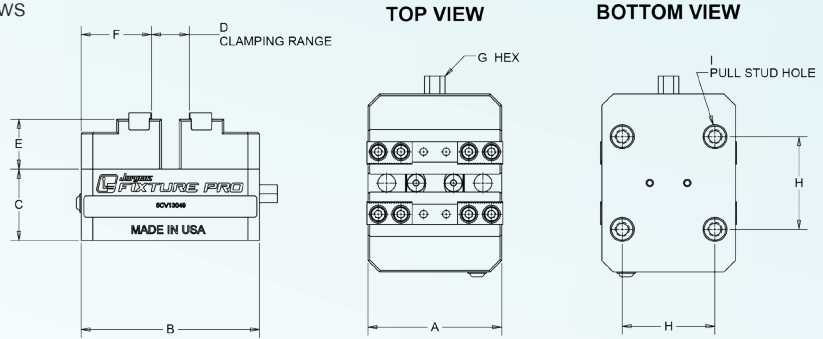

Part Number	A (mm)	B (mm)	C (mm)	D (mm)	E (mm)	F (mm)	G (mm)	H (mm)	I (part no.)	Pull Studs Included	Weight (kg)
5CV13049-IN	75	100	40	12-85	28	39.5	10	52	QL-200800	No	3.1
5CV13050-IN	75	100	40	12-85	28	39.5	10	52	QL-200800	Yes	3.3
5CV13051-IN	75	160	40	12-145	28	39.5	10	52	QL-200800	No	4.0
5CV13052-IN	75	160	40	12-145	28	39.5	10	52	QL-200800	Yes	4.2

130MM SELF-CENTERING VISE

- Available in 160mm or 250mm lengths
- Vises can be ordered with alternate jaw types by adding the one of the following suffixes to a base part number:
 - **A** for aluminum soft jaws
 - **H** for hardened step jaws
 - **S** for steel soft jaws
 - **IN** for insert jaws

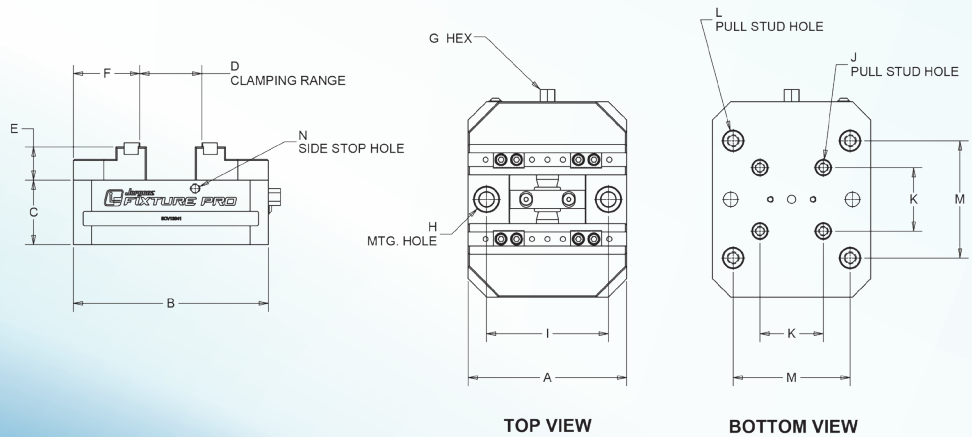

Part Number	A (mm)	B (mm)	C (mm)	D (mm)	E (mm)	F (mm)	G (mm)	H	I (mm)	J (part no.)	K (mm)	L (part no.)	M (mm)	Pull Studs Included	N	Weight (kg)
5CV13041-IN	130	160	53	12-150	27	54	12	12mm QLS	100	QL-200800	52	QL-200805	96	No	M8 X 1.25	7.4
5CV13042-IN	130	160	53	12-150	27	54	12	12mm QLS	100	QL-200800	52	QL-200805	96	Yes (QL-200805)	M8 X 1.25	7.7
5CV13043-IN	130	160	53	12-150	27	54	12	12mm QLS	100	5QP020	60	-	-	No	M8 X 1.25	7.4
5CV13044-IN	130	160	53	12-150	27	54	12	12mm QLS	100	5QP020	60	-	-	Yes	M8 X 1.25	7.7
5CV13045-IN	130	250	53	12-240	27	54	12	12mm QLS	100	QL-200800	52	QL-200805	96	No	M8 X 1.25	10.2
5CV13046-IN	130	250	53	12-240	27	54	12	12mm QLS	100	QL-200800	52	QL-200805	96	Yes (QL-200805)	M8 X 1.25	10.5
5CV13047-IN	130	250	53	12-240	27	54	12	12mm QLS	100	5QP020	60	-	-	No	M8 X 1.25	10.2
5CV13048-IN	130	250	53	12-240	27	54	12	12mm QLS	100	5QP020	60	-	-	Yes	M8 X 1.25	10.5



JAW OPTIONS

- Quick change jaws, no tools required
- Reversible Jaws
- Pull-down design minimizes jaw lift
- Serrated inserts are included with insert jaws

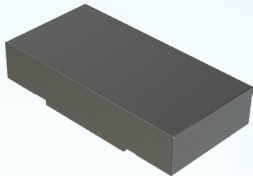

Steel Soft Jaw

Suitable for	Part No.
75mm	5CV13049-SSJ
130mm	5CV13041-SSJ

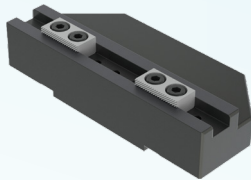

Insert Jaw

Suitable for	Part No.
75mm	5CV13049-INSJ
130mm	5CV13041-INSJ

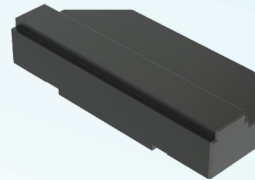

Hardened Step Jaw

Suitable for	Part No.
75mm	5CV13049-HSJ
130mm	5CV13041-HSJ

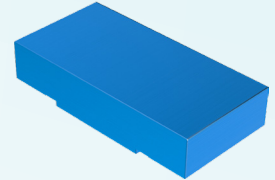

Aluminum Soft Jaw

Suitable for	Part No.
75mm	5CV13049-ASJ
130mm	5CV13041-ASJ

INSERT OPTIONS

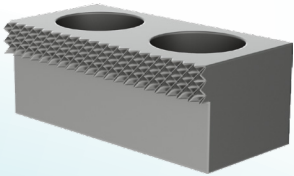

Serrated

Part Number	L (in)
5JISER.5	0.50
5JISER1.0	1.0
5JISER1.5	1.5

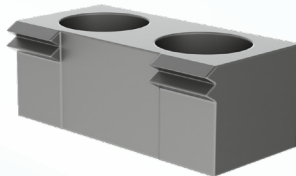

Peak

Part Number	L (in)
5JIDPK.5	0.50
5JIDPK1.0	1.0
5JIDPK1.5	1.5

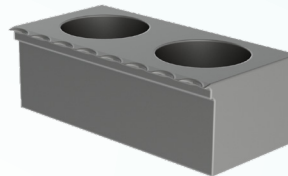

Scalloped

Part Number	L (in)
5JISCA.5	0.50
5JISCA1.0	1.0
5JISCA1.5	1.5

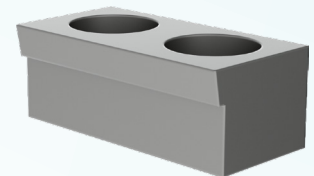

Dovetail

Part Number	L (in)	Angle
5JIDOV.5	0.50	10°
5JIDOV1.0	1.0	10°
5JIDOV1.5	1.5	10°
5JIDOV30.5	.50	30°
5JIDOV301.0	1.0	30°
5JIDOV301.5	1.5	30°

WORLD HEADQUARTERS

15700 S. Waterloo Road
 Cleveland, OH 44110-3898
 ☎ 877-486-1454
 🌐 jergensinc.com
 ✉ info@jergensinc.com

WORKHOLDING SOLUTIONS

☎ 877-426-2504
 🌐 jergensinc.com/workholding
 ✉ workholding@jergensinc.com